



# EVERPURE® HIGH FLOW CSR TWIN-MC<sup>2</sup> SYSTEM

DELIVERS PREMIUM QUALITY WATER FOR COMBINATION APPLICATIONS

High Flow CSR Twin-MC<sup>2</sup> System: EV9330-42  
MC<sup>2</sup> Replacement Cartridge: EV9612-56  
EC210 Prefilter Cartridge: EV9534-26  
SS-IMF Cartridge: EV9799-32



## APPLICATIONS

Combination of coffee brewers, espresso machines, hot chocolate dispensers, fountain and ice machines

Multiple equipment and combinations

## FEATURES • BENEFITS

Proprietary Everpure Micro-Pure® II media inhibits the growth of bacteria  
20" prefilter captures larger dirt particles

NSF Certified under NSF/ANSI Standards 42 and 53

One system provides premium quality water to high flow fountain, coffee and ice machines

Reduces chlorine taste and odor and other offensive contaminants that can adversely affect the taste of beverages

Precoat submicron technology reduces dirt and particles as small as 1/2-micron in size and reduces health contaminants such as cysts

Increases the overall efficiency of foodservice equipment

SR-X with SS-IMF cartridge inhibits scale buildup in ice machines and coffee brewers

Sanitary cartridge replacement is simple, quick and clean. Internal filter parts are never exposed to handling or contamination

## INSTALLATION TIPS

Choose a mounting location suitable to support the full weight of the system when operating

Use 3/4" water line

Fountain equipment connections are made to the outlet part of the system before the SR-X system

Coffee brewer and ice machine connections are made after the SR-X feeder; a tee is required

Install vertically with cartridges hanging down and allow 2-1/2" (6.35 cm) clearance below the cartridge for easy cartridge replacement

Flush cartridges by running water through flushing valve for five (5) minutes at full flow

## OPERATION TIPS

Change cartridges on a regular six (6) month preventative maintenance program

Change cartridges when capacity is reached or when pressure falls below 10 psi (0.7 bar)

Change SS-IMF cartridge before Hydroblend™ compound is completely used up

Change prefilter cartridge when excessively dirty

Always flush the filter cartridge at time of installation and cartridge change

## SIZING

Service Flow Rate: Maximum 3.34 gpm (12.6 Lpm)

Capacity: 18,000 gallons (68,137 L)

# EVERPURE® HIGH FLOW CSR TWIN-MC<sup>2</sup> SYSTEM

## EV9330-42

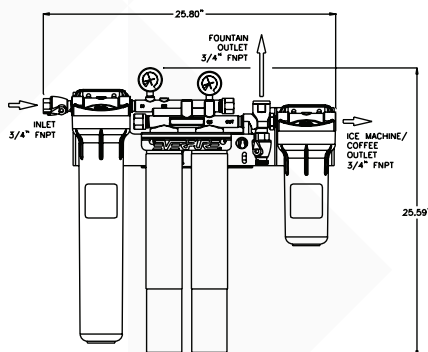

### SPECIFICATIONS

#### Overall Dimensions

25.59" L x 25.8" W x 6.74" D  
(64.9 x 65.5 x 17.1 cm)

#### Connections

Inlet Connection: 3/4"

Outlet Connection: 3/4"

#### Capacity

18,000 gallons (68,137 L)

#### Service Flow Rate

Maximum 3.34 gpm (12.6 Lpm)

#### Pressure Requirements

10 - 125 psi (0.7 - 8.6 bar), non-shock

#### Temperature

35 - 100°F (2 - 38°C)

#### Operating Weight

42 lbs (19 kg)

#### Shipping Weight

30 lbs (13.6 kg)

#### Electrical Connection

None required



System Tested and Certified by NSF International against NSF/ANSI Standard 42 and 53 for the reduction of:

Standard No. 42: Aesthetic Effects  
Chemical Unit  
Taste and Odor Reduction  
Chlorine Reduction  
Mechanical Filtration Unit  
Particulate Reduction, Class I  
Standard No. 53: Health Effects  
Mechanical Filtration Unit  
Turbidity Reduction  
Cyst Reduction  
Asbestos Reduction

The contaminants or other substances removed or reduced by this drinking water system are not necessarily in your water. Do not use with water that is microbiologically unsafe or of unknown quality without adequate disinfection before or after the system. Systems certified for cyst reduction may be used with disinfected water that may contain filterable cysts.

### WARRANTY

Everpure water treatment systems by Pentair® (excluding replaceable elements) are covered by a limited warranty against defects in material and workmanship for a period of five years after date of purchase. Everpure replaceable elements (filter cartridges and water treatment cartridges) are covered by a limited warranty against defects in material and workmanship for a period of one year after date of purchase. See printed warranty for details. Pentair will provide a copy of the warranty upon request.



#### FILTRATION & PROCESSING SOLUTIONS

EVERPURE-SHURFLO WORLD HEADQUARTERS, 1040 MUIRFIELD DRIVE, HANOVER PARK, IL 60133 USA • WWW.EVERPURE.COM  
800.942.1153 MAIN (US ONLY) • 630.307.3000 MAIN • 630.307.3030 FAX • CSEVERPURE@PENTAIR.COM EMAIL

EVERPURE-SHURFLO AUSTRALIA / NEW ZEALAND, 1-21 MONASH DRIVE, DANDENONG SOUTH, VIC, 3175, AUSTRALIA  
1300.576.190 TEL • AU.EVERPURE@PENTAIR.COM EMAIL

EVERPURE-SHURFLO CHINA, 21F CLOUD 9 PLAZA, NO 1118, SHANGHAI, 200052, CHINA  
86.21.3211.4588 TEL • 86.21.3211.4580 FAX • CHINA.WATER@PENTAIR.COM EMAIL

EVERPURE-SHURFLO INDIA, GREEN BOULEVARD, B-9/A, 7TH FLOOR - TOWER B SECTOR 62, NOIDA - 201301  
91.120.419.9444 TEL • 91.120.419.9400 FAX • INDIACUSTOMER@PENTAIR.COM EMAIL

EVERPURE-SHURFLO EUROPE, PENTAIR WATER BELGIUM BVBA, INDUSTRIEPARK WOLFSTEE, TOEKOMSTLAAN, 30 B-2200 HERENTALS, BELGIUM  
+32.(0).14.283.500 TEL • +32.(0).14.283.505 FAX • SALES@EVERPURE-EUROPE.COM EMAIL

EVERPURE-SHURFLO JAPAN INC., HASHIMOTO MN BLDG. 7F, 3-25-1 HASHIMOTO, MIDORI-KU, SAGAMIHARA-SHI KANAGAWA 252-0143, JAPAN  
81.(0)42.775.3011 TEL • 81.(0)42.775.3015 FAX • INFO@EVERPURE.CO.JP EMAIL

EVERPURE-SHURFLO SOUTHEAST ASIA, 390 HAVELOCK ROAD, #04-01, KING'S CENTRE, SINGAPORE 169662  
65.6795.2213 TEL • FAX: 65.6795.2219 FAX • CSEVERPURE@PENTAIR.COM EMAIL

All Pentair trademarks and logos are owned by Pentair, Inc. All other brand or product names are trademarks or registered marks of their respective owners. Because we are continuously improving our products and services, Pentair reserves the right to change specifications without prior notice. Pentair is an equal opportunity employer.